

Zebra's 3S80 3D Sensors

Unsurpassed 3D resolution and accuracy when capturing dynamic scenes

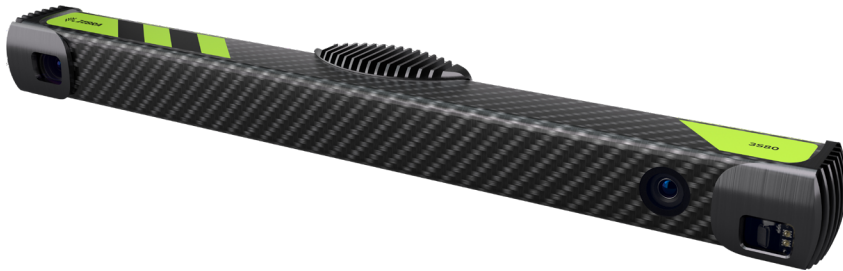

Global commerce continues to move at an accelerating pace. To compete, players need to deliver products more quickly, without compromising yields, quality or efficiency. Automating 3D inspection and dimensioning tasks can increase manufacturing productivity and logistical throughput. But maintaining efficiency and accuracy at speed demands more sophisticated machine vision solutions.

Zebra's 3S Series of 3D Sensors Delivers It All

Leveraging patented parallel structured light technology, Zebra's 3S80 3D sensors offer the industry's highest 3D image resolution and accuracy when capturing dynamic scenes.

Designed for manufacturing inspection and dimensioning applications, Zebra's two 3S80 sensor models are differentiated by their respective scanning volumes:

- Model 3S80-4M is optimal for scanning medium-sized objects and scenes
- Model 3S80-4L extends the dynamic scanning range up to 3 m to acquire 3D data for the largest objects and biggest volumes. At its optimal scanning distance of 1.25 m, the sensor captures high-resolution point clouds of objects within an area measuring 1027 x 836 mm.

Each sensor can acquire up to 2 million 3D points (1680 x 1200) in a 45-ms scan and render the data in detailed RGB-colored point clouds. This high-speed and high-resolution acquisition means there is no motion blur when imaging objects moving on a conveyor and provides true per-pixel measurement.

3S80 3D sensors: At a Glance

- **Fast acquisition of 3D data** – Patented Parallel Structured Light technology enables parallel construction of multiple virtual images within one exposure window. As a result, 3S80 sensors can accurately capture high-resolution 3D images of moving objects without motion artifacts.
- **Shorter cycle times** – Paired with Parallel Structured Light technology, the 3S80's 2-MP sensor enables faster bin picking with shorter cycle times, fewer errors and faster error recovery. It also supports ambient light suppression to deliver optimal results.
- **Large scanning volume** – The scanning volume of 3S80 sensors ranges up to three meters, allowing it to capture 3D data of both large and very small objects.
- **Plug-and-play integration** – The 3S80 sensors easily pair with Zebra's powerful 4Sight EV7 vision controller and Aurora software. Just point the 3S80 device at a scene to capture an accurate high-density point cloud.
- **Patented CMOS sensor** – Combined with Parallel Structured Light technology, the CMOS sensor within 3S80 cameras can quickly and accurately capture moving and stationary objects.
- **Power-over-ethernet (PoE) and 24V powering options** – A single PoE cable provides both power and a data connection.

The 3S80—Vision without limits. Experience the difference with Zebra.
For more information, visit www.zebra.com/3S-series

Sophisticated Performance, Simple Implementation

Though highly advanced in performance, 3S80 3D sensors are as simple to implement as the rest of Zebra's machine vision portfolio. The plug-and-play hardware — comprising a CMOS camera, laser projection unit, and GPU processor — is designed to support AIA's GigE™ Vision standard. Compatible with PoE+ or 24V pluggability, each device integrates easily with existing machine vision systems. Users simply plug in and point the camera at a scene to begin capturing accurate high-density point clouds without sacrificing quality or speed.

Powered by Zebra Aurora™ Software and 4Sight EV7 Vision Controller

Every 3S80 3D sensor comes bundled with Zebra's Aurora Design Assistant™ or Aurora Vision Studio™ software to quickly configure and deploy complex deep learning and traditional machine vision applications. Add Zebra's 4Sight EV7 for demanding single high-rate or multi-camera imaging and machine vision applications.

Easy to Deploy and Run

Zebra's Aurora Design Assistant and Aurora Vision Studio software makes it easy for users to deploy and run applications without having to learn or implement multiple software environments. Both software platforms enable 3S80 3D sensors to leverage a deep collection of tools for image capture, processing, analysis, annotation, display and archiving.

Deep Learning to Further Enhance Solution Quality

Use 3S80 3D sensors with Zebra's advanced deep learning tools to solve difficult machine vision problems that would be impossible to achieve with traditional tools. Locate complex and irregular surface defects and enable other challenging 3D vision tasks to improve the quality and operational efficiency of your workflow.

Zebra 3S Series Lineup

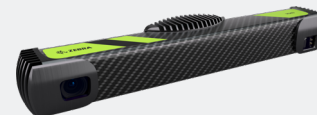

3S40



3S80-4M



3S80-4L

Specifications

3S80-4M

Device Characteristics

Dimensions	16.9 x 2.7 x 3.3 in 428 x 68 x 85 mm
Weight	2.3 lbs / 1050 g
Baseline	13.8 in / 350 mm
Power	PoE+ or 24V
Data connection	1 Gbit Ethernet

Performance Characteristics

3D sensing technology	Parallel Structured Light
Output data	3D points (x y z) normals (x y z) depth map (z) color image (RGB) texture (grayscale intensity) confidence (float)
Scanning range	19.6–37 in / 497–939 mm
Optimal scanning distance (sweet spot)	25.7 in / 653 mm
Scanning area (at sweet spot)	23.1 x 17.5 in / 588 x 444 mm

Operation Mode/Scene

Scanner/Static

Camera/Dynamic

Operation Mode/Scene	Scanner/Static	Camera/Dynamic
Resolution	2 million 3D points (1680 x 1200)	up to 2 million 3D points (1680 x 1200)
Color picture resolution	2 MP mapped on 3D data (2D data up to 8 MP)	2 MP mapped on 3D data (2D data up to 8 MP)
Point-to-point distance (at sweet spot)	0.015 in / 0.37 mm	0.021 in / 0.55 mm at 0.9 MP 0.015 in / 0.37 mm at 2 MP
Calibration accuracy (1 σ)	0.009 in / 0.25 mm	0.02 in / 0.5 mm
Temporal noise (1 σ)	0.002 in / 0.05 mm	0.003 in / 0.1 mm
Maximum fps	2 fps	20 fps at 0.9 MP 5 fps at 2 MP

User Environment

Temperature working range	full: 32–104° F / 0–40° C optimal: 72–77° F / 22–25° C
---------------------------	---

Field of View



3S80-4M

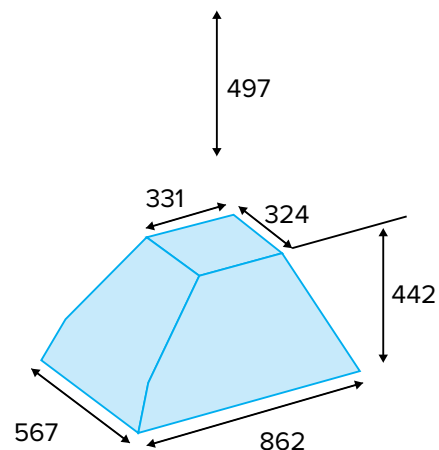

Specifications

3S80-4L

Device Characteristics	
Dimensions	24.7 x 2.7 x 3.4 in 628 x 68 x 85 mm
Weight	2.5 lbs / 1,150 g
Baseline	21.7 in / 550 mm
Power	PoE+ or 24 V
Data connection	1 Gbit Ethernet

Performance Characteristics	
3D sensing technology	Parallel Structured Light
Output data	3D points (x y z) normals (x y z) depth map (z) color image (RGB) texture (grayscale intensity) confidence (float)
Scanning range	30.6–119.4 in / 778–3,034 mm
Optimal scanning distance (sweet spot)	49.3 in / 1252 mm
Scanning area (at sweet spot)	40.4 x 32.9 in / 1027 x 836 mm

Operation Mode/Scene	Scanner/Static	Camera/Dynamic
Resolution	2 million 3D points (1680 x 1200)	up to 2 million 3D points (1680 x 1200)
Color picture resolution	2 MP mapped on 3D data (2D data up to 8 MP)	2 MP mapped on 3D data (2D data up to 8 MP)
Point-to-point distance (at sweet spot)	0.03 in / 0.720 mm	.04 in / 1.05 mm at 0.9 MP 0.028 in / 0.72 mm at 2 MP
Calibration accuracy (1 σ)	0.035 in / 0.900 mm	0.05 in / 1.25 mm
Temporal noise (1 σ)	0.004 in / 0.100 mm	0.006 in / 0.15 mm
Maximum fps	2 fps	20 fps at 0.9 MP 5 fps at 2 MP

User Environment	
Temperature working range	full: 32–104° F / 0–40° C optimal: 72–77° F / 22–25° C

Field of View

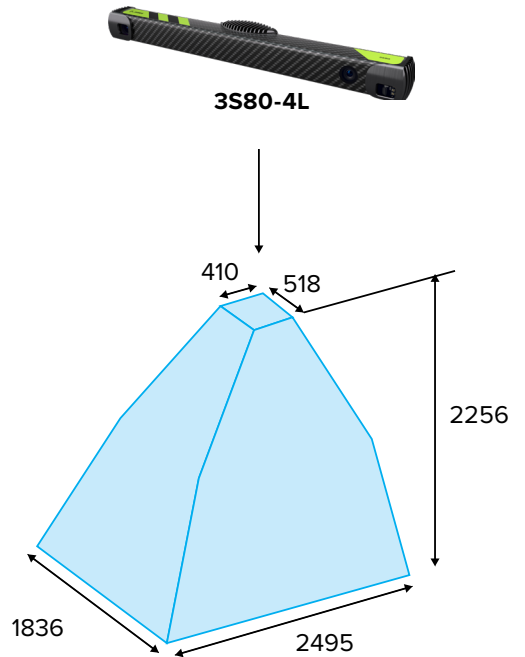

NA and Corporate Headquarters
+1 800 423 0442
inquiry4@zebra.com

Asia-Pacific Headquarters
+65 6858 0722
contact.apac@zebra.com

EMEA Headquarters
zebra.com/locations
contact.emea@zebra.com

Latin America Headquarters
zebra.com/locations
lla.contactme@zebra.com